

Hitachi, with more than 100 years of legacy worldwide and with over 3 GW installation base of PV Central Solar Inverters in India, brings to you the PV STRING INVERTER with latest, efficient & flexible design to maximize the energy yield for large commercial & utility solar projects. With highly efficient conversion technology, this HIVERTER Si Series PV String Solar Inverter is available from 4.4 kW to 70 kW range with 3 Phase output and 1.1 kW to 7.5 kW range with 1 Phase output.

- Best suitable for heavy industries and large commercial establishments in India
- Wide range of 1.1 kW to 70 kW Inverters offers more flexibility as per project design
- Real time precise MPPT algorithm to ensure highest efficiency up to 98.6%
- Intelligent grid management features first of its kind IV curve diagnostics feature
- A robust IP65 enclosure allowing hassle free outdoor installations
- Low maintenance cost
- Safety assured through its anti islanding, RCMU, ground fault monitoring

String Inverter Technology

Intelligent Power Management

- LVRT / ZVRT protections
- Self-power reducer in case of over frequency
- Fully adjustable reactive power & power factor for different grids
- Real time MPPT algorithm

Built-In Protection Functions

- Over current, Over load
- O/ V & U/V protection
- Anti-islanding, Current leakage
- Over temperature protection
- Over frequency, Under-frequency
- SPD Type III, Type II (Optional for 20-33 kW models)

Humanized Functions

- Audible & visible alarming function
- Remote system connection or disconnection
- Remote firmware upgrade
- Remote monitoring
- Separate section for power & termination

Highlights

- Wide DC input range from 250 V to 950 V
- Highest AC output range +/- 25%
- Up to 3 Independent MPPT to ensure optimal energy harvest
- MPPT accuracy is up to 99.9 %, max euroefficiency 98.4 %
- Wide ambient temp range -25°C to 60°C
- IP 65 protection for Indoor & outdoor application
- Low sensitivity to the grid disturbance to avoid unnecessary breakdo
- User friendly interface like RS 232 / RS 485 / Wi-Fi
- Easy to read LCD display with all operational status & necessary data
- Reactive power controller
- Type II SPD String current monitoring

Advantages

More Reliability

- Usage of only higher voltage level capacitor
- Support four uni-polar output relays (effective heat dissipation, longer life)

Higher Efficiency

- "T" type 3 level topology provides higher efficiency

More Convenience

- All information is available on a 4" large screen
- Availability of four separate buttons give easy operation
- Equipped with compact ACDB & DCDB (optional*)

(*Optional for 20-33 kW Models)

Safer

- Equipped with leakage current detection components
- Use professional solar AC connectors as output

Better Monitoring

- RS485 / Wi Fi / GPRS / Ethernet
- Local data is recorded in SD card for 25 years
- IV curve scanning technology, catch MPPT easily and quickly

Better Appearance

- Die-casting housings
- Go through anti-corrosion and anti-rust protection processes

Grid Tied Solar String Inverters

Highly Efficient Conversion Technology

4.4 kW to 70 kW (3Ph.)
1.1 kW to 7.5 kW (1Ph.)

Generating

3 GW+

Renewable Power
in Indian Solar Sector
through
Central Inverters



Hitachi Hi-Rel Power Electronics Pvt. Ltd.

Registered Office (Ahmedabad): B-52, Corporate House, Near Judges Bungalow, Bodakdev, Ahmedabad-380054, Gujarat, India. Tel: +91-79-6604 6200, Fax: +91-79-6604 6201

Sanand Mfg. Works: Survey # 3 & 4, Sanand GIDC II, Industrial Estate, Nr. Bol Village, Chharodi, Sanand-382110, Gujarat, India. Tel: +91-2717-678777, Fax: +91-2717-678700

Gandhinagar Mfg. Works: B-14/1 & 171, GIDC Electronics Zone, Sector-25, Gandhinagar-382044, Gujarat, India. Tel: +91-79-6170 0500, +91-79-2328 7180/81, Fax: +91-79-23287182

Email: contact@hitachi-hirel.com | **URL:** www.hitachi-hirel.com

[f](#) /hitachihirel [in](#) /company/hitachihirel [yt](#) /hitachihirelindia

In the spirit of innovation, specifications and features are subject to change without notice.

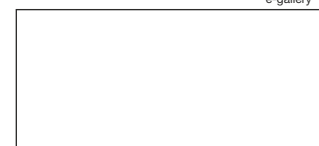

Printed in India

Ver.1.0/2019/ACS1 Spotlight

Efficiency Curve

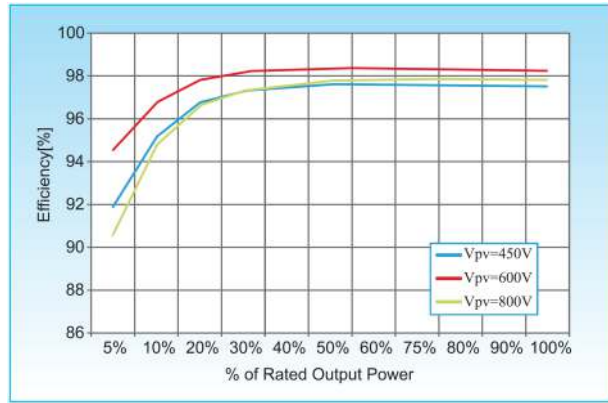

(HIVERTER Si - 20 kW to 33 kW Models)

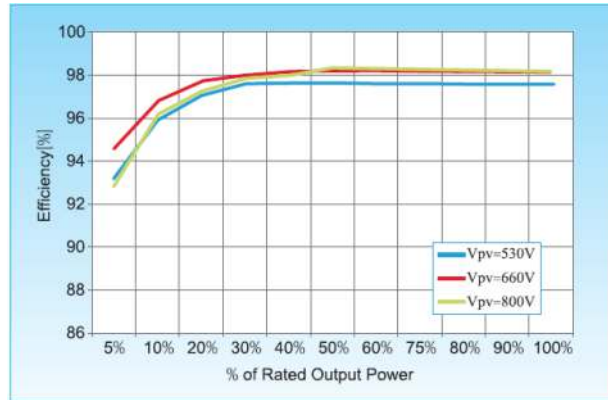

(HIVERTER Si - 50 kW to 70 kW Models)

High-yield

- Max 98.6% efficiency
- Real time precise MPPT algorithm for max harvest
- Wide input voltage operation range from 250 V to 950 V

All in one, Flexible and economical system solutions

- DC switch
- Built-in PV combiner
- Power management unit
- Optimum selection for big PV plants, commercial buildings.
- Inbuilt type II DC surge protection device[#]
- Inbuilt type II AC surge protection device[#]

Low maintenance cost

- Rust-free aluminum covers
- Flexible monitoring solution
- Multi-function relay can be configured to show various inverter information

Intelligent grid management

- ZVRT support
- Reactive power adjustable
- Self-power reducer when over frequency
- Remote active / reactive power limit control

[#]Optional for 20-33 kW Models

Single Line Diagram

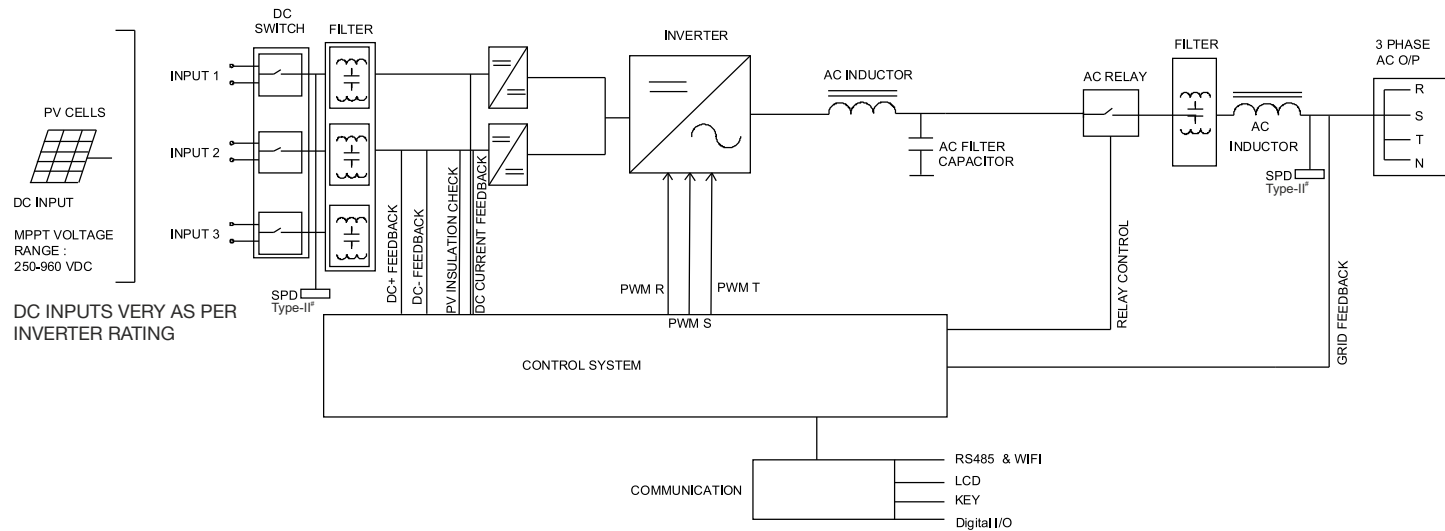

Globally Renowned Component Partners

MOSIGBT 	IC 	Fuse 	Current Transducer
Capacitor 	Diode 	Relay 	MCU

Technical Specifications - Solar String Inverter - 1.1 kW to 3.3 kW (1Ph.)

HIVERTER-Si Series Single Phase, Single MPPT	Si 1.1K-H3	Si 1.6K-H3	Si 2.2K-H3	Si 2.7K-H3	Si 3K-H3	Si 3.3K-H3
Input (DC)						
Recommended PV Input Power	1500W	2200W	3000W	3700W	4100W	4500W
Max. Input Voltage	500V			550V		
Aux. Open Voltage	60V					
Start-up Input Voltage	70V					
Rated Input Voltage	360V					
MPPT Voltage Range	50-500V			50-550V		
Full Load DC Voltage Range	110-450V	150-450V	200-450V	250-500V	275-500V	300-500V
Max. Input Current MPPT	12A					
Max. DC Input Short Circuit Current per MPPT	15A					
Number of MPPT/ String per MPPT	1 / 1					
Input Terminal Type	MC4 / H4					
Output (AC)						
Rated Power	1100W	1600W	2200W	2700W	3000W	3300W
Max. AC Power	1100VA	1600VA	2200VA	2700VA	3000VA	3300VA
Rated Output Current	4.8A	7A	9.6A	11.8A	13A	14.3A
Max. Output Current	5.3A	7.7A	10.6A	13A	14.5A	16A
Nominal Grid Voltage	L/N/PE, 220VAC, 230VAC, 240VAC					
Grid Voltage Range	180VAC-276VAC (According to local standard)					
Nominal Frequency	50 / 60Hz					
Grid Frequency Range	45-55Hz/54-66Hz (According to local standard)					
THDi	<3%					
Power Factor	1default (adjustable ±0.8)					
Efficiency						
Max. Efficiency up to	97.5%			97.7%		
European Weighted Efficiency up to	96.9%			97.2%		
MPPT Adaptation Efficiency	>99.9%					
Protection						
Anti-islanding Protection	Yes					
DC Reverse Polarity Protection	Yes					
Over Temp Protection	Yes					
Leakage Current Protection	Yes					
Over Voltage Protection	Yes					
Over Current Protection	Yes					
Earth Fault Protection	Yes					
SPD	MOV: Type III standard					
Communication						
Standard Communication Mode	RS485, WiFi / GPRS / Ethernet (optional), USB					
Operation Data Storage	25 years					
General Data						
Topology	Transformer-less					
Ambient Temperature Range	-30°C ~ +60°C					
Allowable Relative Humidity Range	0-100%					
Noise	<25dB					
DC Switch	Optional					
Cooling	Natural convection					
Max. Operating Altitude	2000m					
Dimension	303 x 260.5 x 118mm			321 x 260.5 x 131.5mm		
Support Bracket	Wall-mounted					
Weight	5.5kg			6.3kg		
Display	LCD+LED					
Degree of Protection	IP65					
Standard						
EMC	EN 61000-6-1, EN 61000-6-2, EN 61000-6-3, EN 61000-6-4					
Safety Standards	IEC 62116, IEC 61727, IEC 61683, IEC 60068(1,2,14,30), IEC 62109-1/2					
Grid Standards	AS 4777, VDE V 0124-100, VDE V 0126-1-1, VDE-AR-N 4105, EN 50438, G83/2, C10/11, RD 1699					

Technical Specifications - Solar String Inverter - 3 kW to 7.5 kW (1Ph.)

HIVERTER-Si Series Single Phase, Dual MPPT	Si 3K-H2	Si 3.6K-H2	Si 4K-H2	Si 4.6K-H2	Si 5K-H2	Si 6K-H2	Si 7.5K-H2
Input (DC)							
Recommended PV Input Power	3500W	4000W	4400W	5000W	5500W	6600W	8300W
Max DC Power for Single MPPT	2000W	2400W	2600W	3000W	3000W	3500W	2*2750W/ 2750W
Number of Independent MPPT	2						
Number of DC Inputs	1 / 1						2 / 1
Max. Input Voltage	600V						
Start-up Input Voltage	120V						
Rated Input Voltage	360V						
MPPT Voltage Range	90-580V						
Full Load DC Voltage Range	160V-520V	180V-520V	200V-520V	230V-520V	250V-520V	300V-520V	250V-520V
Max. Input Current per MPPT	11A / 11A						22A / 11A
Maximum DC Input Short Circuit Current per MPPT	14A						28 / 14A
Output							
Rated Power	3000W	3680W	4000W	4600W	5000W	6000W	7500W
Max. AC Power	3000VA	3680VA	4000VA	4600VA	5000VA	6000VA	7500VA
Max. Output Current	13.7A	16.8A	18.2A	21A	22.8A	27.3A	32.6A
Nominal Grid Voltage	L/N/PE, 220VAC, 230VAC, 240VAC						
Grid Voltage Range	180VAC-276VAC (According to local standard)						
Nominal Frequency	50 / 60Hz						
Grid Frequency Range	45~55Hz/54~66Hz (According to local standard)						
Active Power Adjustable Range	0 ~ 100%						
THDI	<3%						
Power Factor	1 default (adjustable ±0.8)						
Power Limit Export	Zero export or adjustable power limit export						
Performance							
Max. Efficiency up to	98.0%						98.2%
European Weighted Efficiency up to	97.5%						97.6%
Self-consumption at Night	<1W						
Feed-in Start Power	50W						
MPPT Efficiency	>99.9%						
Protection							
DC Reverse Polarity Protection	Yes						
DC Switch	Optional						
Protection Class/Overvoltage Category	I / III						
Input/Output MOV (II)	Yes						
Safety Protection	Anti islanding, RCMU, Ground fault monitoring						
SPD	MOV: Type III standard / Type II optional						
Communication							
Power Management Unit	According to certification and request						
Standard Communication Mode	RS485, Wifi / Ethernet / GPRS (optional), SD card (optional)						
Operation Data Storage	25 years						
General Data							
Ambient Temperature Range	-25°C ~ +60°C						-30°C ~ +60°C
Topology	Transformer-less						
Degree of Protection	IP65						
Allowable Relative Humidity Range	0~100%						
Max. Operating Altitude	2000m						
Noise	<25dB						
Weight	11.5kg						18kg
Cooling	Natural convection						
Dimension	405 x 315 x 135mm						467 x 352 x 157mm
Display	LCD display						
Standard							
EMC	EN 61000-6-2, EN 61000-6-3, EN 61000-3-2, EN 61000-3-3, EN 61000-3-11, EN 61000-3-12						
Safety Standards	IEC62109-1/2, IEC62116, IEC61727, IEC-61683, IEC60068(1,2,14,30)						
Grid Standards	A S/NZS 4777, VDE V 0124-100, V 0126-1-1, VDE-AR-N 4105, CEI 0-21, EN50438/EN50549, G83/G59/G98/G99, NB/T32004; ABNT NBR 16149/16150 (for SOFAR3KTLM- G2, SOFAR5KTLM- G2& 7.5KTLM)						

Technical Specifications - Solar String Inverter - 4.4 kW to 12 kW (3Ph.)

HIVERTER-Si Series Three Phase	Si 4.4K	Si 5.5K	Si 6.6K	Si 8.8K	Si 11K	Si 12K
Input (DC)						
Recommended PV Input Power	4800W	6000W	7200W	9600W	12000W	14400W
Max DC Power for Single MPPT	4500W	5700W	6250W	6200W	6200W	6850W
Number of Independent MPPT	2					
Number of DC Inputs	1 for each MPPT					
Max. Input Voltage	1000V					
Start-up Input Voltage	180V					
Rated Input Voltage	600V					
MPPT Voltage Range	160V - 900V					
Full Load DC Voltage Range	190V-850V	240V-850V	290V-850V	380V-850V	480V-850V	575V-850V
Max. Input Current per MPPT	11A / 11A					
Max. DC Input Short Circuit Current per MPPT	14A					
Output (AC)						
Rated Power	4400W	5500W	6600W	8800W	11000W	12000W
Max. AC Power	4400VA	5500VA	6600VA	8800VA	11000VA	13200VA
Max. Output Current	6.4A	8.0A	9.6A	12.8A	15.9A	19.1A
Nominal Grid Voltage	3/N/PE, 220/380VAC, 230/400VAC, 240/415VAC					
Grid Voltage Range	310VAC-480VAC (According to local standard)					
Nominal Frequency	50 / 60Hz					
Grid Frequency Range	45Hz-55Hz/54Hz-66Hz (According to local standard)					
Active Power Adjustable Range	0 ~ 100%					
THDi	<3%					
Power Factor	1 default (adjustable ±0.8)					
Power Limit Export	Zero export or adjustable power limit export					
Performance						
Max Efficiency up to	98%			98.3%		
European Weighted Efficiency up to	97.50%			98%		
Self-Consumption at Night	<1W					
MPPT Efficiency	>99.9%					
Protection						
DC Reverse Polarity Protection	Yes					
DC Switch	Yes					
Safety Protection	Anti-islanding, RCMU, Ground fault monitoring					
ARPC	Anti-reverse power controller (optional)					
Communication						
Power Management Unit	According to certification and request					
Standard Communication Mode	RS485, Wifi / Ethernet / GPRS (optional), SD card					
Operation Data Storage	25 years					
General Data						
Ambient Temperature Range	-25°C ~ +60°C					
Topology	Transformer-less					
Degree of Protection	IP65					
Allowable Relative Humidity Range	0~100%					
Max. Operating Altitude	2000m					
Noise	<29dB					
Weight	21kg			22kg		
Cooling	Natural					
Dimension	457 x 452 x 202mm					
Display	LCD display					
Standard						
EMC	EN 61000-6-1, EN 61000-6-2, EN 61000-6-3, EN 61000-6-4, EN 61000-3-2, EN 61000-3-3, EN 61000-3-12, EN 61000-3-11					
Safety Standards	IEC62109-1/2, IEC62116, IEC61727, IEC-61683, IEC60068(1,2,14,30), IEC60255					
Grid Standards	AS/NZS 4777, VDE V 0124-100, V 0126-1-1, VDE-AR-N 4105, CEI 0-21, EN50438/EN50549, G83/G59, Rd1699, UTE C15-712-1, EN50530, NB/T32004					

Technical Specifications - Solar String Inverter - 20 kW to 33 kW (3Ph.)

HIVERTER-Si Series Three Phase		Si 20K	Si 25K	Si 30K	Si 33K
Input (DC)	Recommended PV Input Power	26000W	32500W	39000W	42900W
	Max. DC Power for Single MPPT	13000W	16000W	18000W	20000W
	No. of Independent MPPT	2			
	No. of DC Inputs	2 for each MPPT	3 for each MPPT		
	Max. Input Voltage	1100V			
	Start-up Input Voltage	250V			
	Rated Input voltage	620V			
	MPPT Voltage Range	230V-960V			
	Full Load DC Voltage Range	480V-850V	460V-850V	520V-850V	580V-850V
	Max. Input MPPT Current	24A/24A	28A/28A	30A/30A	30A/30A
	Max. DC Input Short Circuit Current per MPPT	30A	35A	37.5A	37.5A
	Output (AC)	Rated Power	20000W	25000W	30000W
Max. AC Power		22000VA	27500VA	33000VA	36300VA
Max. Output Current		32A	40A	48A	53A
Nominal Grid Voltage		3/N/PE, 220/380VAC, 230/400 VAC, 240/415VAC			
Grid Voltage Range		310VAC-480VAC (According to local standard)			
Nominal Frequency		50/60Hz			
Grid Frequency Range		45Hz-55Hz/54Hz-66Hz (According to local standard)			
Active Power Adjustable Range		0~100%			
THDi		<3%			
Power Factor		1 default (adjustable ±0.8)			
Performance	Max Efficiency up to	98.2%	98.4%	98.4%	98.6%
	European Weighted Efficiency up to	98.0%	98.2%	98.2%	98.2%
	Self-consumption at Night	<1 W			
	MPPT Efficiency	>99.9%			
Protection	DC Reverse Polarity Protection	Yes			
	DC Switch	Yes			
	Protection Class/Overvoltage Category	I/III			
	Safety Protection	Anti-islanding, RCMU, Ground fault monitoring			
ARPC	Anti-reverse power controller (optional)				
Communication	Power Management Unit	According to certification and request			
	Standard Communication Mode	RS485, WiFi / Ethernet / GPRS (optional), SD card			
	Operation Data Storage	25 years			
General Data	Ambient Temperature Range	-25°C ~ +60°C			
	Topology	Transformer-less			
	Degree of Protection	IP65			
	Allowable Relative Humidity Range	0-100%			
	Max. Operating Altitude	2000m			
	Noise	< 30 dB	< 45 dB		
	Weight	37kg			
	Cooling	Natural	Fan		
	Dimensions	666 x 512 x 254mm			
	Display	LCD display			
Standard	EMC	EN 61000-6-2, EN 61000-6-3, EN 61000-3-12, EN 61000-3-11			
	Safety Standards	IEC62109-1/2, IEC62116, IEC61727, IEC-61683, IEC60068(1,2,14,30), IEC60255			
	Grid Standards	A S/NZS 4417, VDE V 0124-100, V 0126-1-1 VDE-AR-N 4105, CEI 0-21/CEI 0-16, EN50438/EN50549, G59, P.O. 12.3, RD1699, UTE C15-712-1, EN50530, NB/T32004			

Technical Specifications - Solar String Inverter - 50 kW to 70 kW (3Ph.)

HIVERTER-Si Series Three Phase		Si 50K	Si 60K	Si 70K(HV)
Input (DC)	Recommended PV Input Power	55000W	66000W	77000W
	Max. DC Power for Single MPPT	22000W/16000W/16000W	22000W/22000W/22000W	26000W/26000W/26000W
	No. of Independent MPPT	3		
	No. of DC Inputs	4/3/3	4/4/4	
	Max. Input Voltage	1000V		
	Start-up Input Voltage	250V		
	Rated Input Voltage	600V	600V	700V
	MPPT Voltage Range	250V-960V		
	Full Load DC Voltage Range	530V-800V	530V-800V	660V-800V
	Max. Input MPPT Current	40A/30A/30A	40A/40A/40A	40A/40A/40A
	Max. Input Current per String	12A		
	Max. DC Input Short Circuit Current per MPPT	48A/36A/36A	48A	48A
Output (AC)	Rated Power	50000W	60000W	70000W
	Max. AC Power	55000VA	60000VA	70000VA
	Max. Output Current	80A	90A	90A
	Nominal Grid Voltage	3/N/PE, 220/380VAC, 230/400VAC, 240/415VAC		3/N/PE or 3/PE, 277/480VAC
	Grid Voltage Range	310VAC-480VAC (According to local standard)		422VAC-528VAC (According to local standard)
	Nominal Frequency	50 / 60Hz		
	Grid Frequency Range	40Hz-55Hz/54Hz-66Hz (According to local standard)		
	Active Power Adjustable Range	0 ~100%		
	THDi	<3%		
	Power Factor	1 default (adjustable ± 0.8)		
Performance	Max Efficiency up to	98.5%	98.6%	98.6%
	European Weighted Efficiency up to	98.3%	98.4%	98.4%
	Self Consumption at Night	<1W		
	MPPT Efficiency	>99.9%		
Protection	DC Reverse Polarity Protection	Yes		
	DC Switch	Yes		
	Protection Class/Overvoltage Category	I/III		
	Input/Output SPD (II)	PV: Type II standard, AC: Type II		
Safety Protection	Anti-islanding, RCMU, ground fault monitoring			
ARPC	Anti-reverse power controller (optional)			
Communication	Power Management Unit	According to certification and request		
	Standard Communication Mode	RS485, Wifi / Ethernet / GPRS (optional), SD card, Multi-function relay		
	Operation Data Storage	25 years		
General Data	Ambient Temperature Range	-25°C ~ +60°C		
	Topology	Transformer-less		
	Degree of Protection	IP65		
	Allowable Relative Humidity Range	0~100%		
	Max. Operating Altitude	4000m		
	Noise	≤ 60 dB		
	Weight	68kg	70kg	
	Cooling	Fan		
	Dimensions	713 x 737 x 297 mm		
	Display	LCD display		
Standard	EMC	EN 61000-6-2, EN 61000-6-4, EN 61000-3-11, EN 61000-3-12		
	Safety Standards	IEC62109-1/2, IEC62116, IEC61727, IEC-61683, IEC60068(1,2,14,30)		
	Grid Standards	AS/NZS 4777, VDE V 0124-100, V 0126-1-1, VDE-AR-N 4105, BDEW, CEI 0-21/CEI 0-16, UNE 206 007-1, EN50438/EN50549, G59, EN50530, NB/T32004		